

**Switch actuator REG-K/12x230/10 with manual mode**

Operating instructions

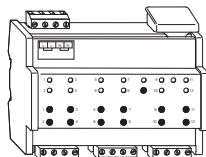

Art. no. MTN649212

**For your safety**

**DANGER**
**Risk of fatal injury from electrical current.**

All work on the device should only be carried out by trained and skilled electricians. Observe the country-specific regulations as well as the valid KNX guidelines.

**CAUTION**
**The device could be damaged.**

- Only operate the device according to the specifications stated in the Technical data.
- All devices that are installed next to the actuator must be equipped with at least basic insulation.

**Getting to know the switch actuator**

The switch actuator REG-K/12x230/10 with manual mode (referred to below as the **actuator**) can switch twelve loads via separate, floating make contacts.

You can switch the actuator to manual operation and check that it works even without ETS programming, and you can control the connected loads directly at the actuator in the event of a bus failure.

The actuator has a bus coupler. It is installed on a DIN rail, with the bus connection made via a bus connecting terminal. A data rail is not required.

It is supplied with power both from the bus voltage and from the mains. This makes three different operating modes possible:

**Bus and mains supply**

This is a standard operating mode. The actuator is supplied by both the bus and mains voltages.

**Bus supply only**

The actuator is operated solely in bus mode. Manual operation is possible.

**Mains supply only**

It may only be possible to operate the actuator manually, without bus communication. You can activate the loads directly using the channel keys.

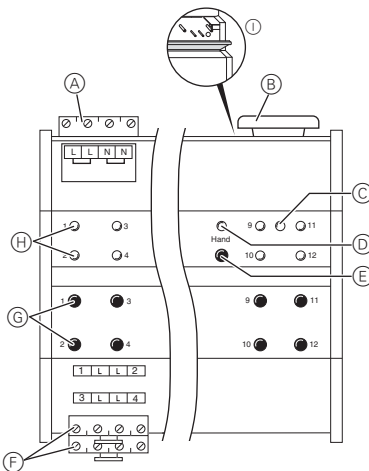

- Ⓐ Mains connection: The actuator has two connecting terminals each for the N and L cables (looping is possible).
- Ⓑ Under the cable cover: Bus connecting terminal, programming button and programming LED (red)
- Ⓒ Operating LED "RUN" (green)
- Ⓓ Manual operation LED "Manual" (red)
- Ⓔ Manual operation key "Manual"
- Ⓕ Channel terminals for load voltage
- Ⓖ Channel keys for manual control of the corresponding channel, only respond when manual operation is switched on
- Ⓗ Channel status LEDs (yellow) for the corresponding channel
- Ⓘ Flap forward to open

**Mounting the actuator**

- ① Set the actuator onto the DIN rail.

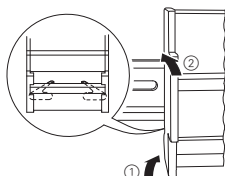

- ② Connect KNX.

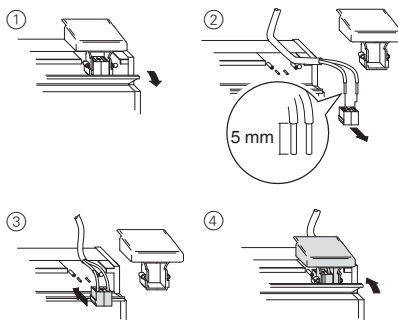
**WARNING**
**Risk of fatal injury from electrical current. The device could become damaged.**

Safety clearance must be guaranteed in accordance with IEC 60664-1. There must be at least 4 mm between the individual cores of the 230 V supply cable and the KNX line.

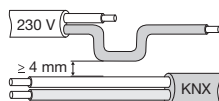
**DANGER**
**Risk of fatal injury from electrical current.**

Voltage may be present at the outputs when the mains voltage is connected to the system. If subjected to strong vibrations during transportation, the switch contacts might change to the enabled state.

After connecting the bus/mains voltage, wait at least 30 seconds. The relays of the channels will be switched off. Set the relays of the channels to the position desired simply by switching "On/Off".

- ③ Connect the mains voltage.
- ④ Switch on bus/mains voltage.
- ⑤ Wait at least 30 seconds.
- ⑥ Set the relays of the channels to the position desired simply by switching "On/Off".

**CAUTION**
**The actuator can be damaged. Protect:**

- Connections with a 10-A circuit breaker connected upstream. If you use separate fuse for the connections of two related switching channels, these must be on the same phase.
- If the mains voltage is looped, protect the mains connection with a 10-A circuit breaker connected upstream as well.

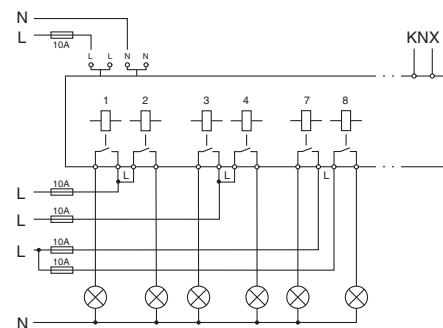

- ⑦ Connect the load
- ⑧ Connect the load voltage.

Now you can check the functionality of the actuator and the connected loads without having to load the application from the ETS. (See the "Operating the actuator" section.)

**Putting the actuator into operation**

- ① Press the programming button. The programming LED lights up.
- ② Load the physical address and application into the device from the ETS.

The programming LED goes out.

The operating LED lights up: The application was loaded successfully, the device is ready for operation.

**Operating the actuator**

Normally, you control connected devices using push-buttons or by remote control. However, you can also switch the actuator to manual operation and then switch each channel on and off manually using its channel keys. In order to be able to do this, the ETS parameter "Manual operation enabled" must be set to "enabled" and mains or bus voltage must be present.

### Manual operation before downloading the application for the first time

Immediately after the initial installation, you can switch the actuator to manual operation, e.g. in order to test the operation of the connected devices.

### Manual operation with the ETS setting "Bus and manual operation"

In manual operation, the actuator also responds to KNX telegrams. The command last received is given priority. Exception: Safety and security alarms always have priority with this setting.

### Manual operation with the ETS setting "Manual operation only"

In manual operation, the actuator does not respond to KNX telegrams, nor to safety alarms. This setting can be useful when carrying out maintenance, for example.

### CAUTION Loads could be damaged.

When operating loads in "Manual operation only" using the channel keys, prioritised safety functions (e.g. priority control) no longer work. To prevent damage, you should therefore be very careful when operating manually.

**i** Make sure that the ETS parameter "Manual operating mode" is set to "Bus and manual operation" (**not** "Manual operation only"), when you hand over the system to the operator.

Time-limited manual operation is another function that can be set in the ETS. With this function, you can set a time period after which manual operation (including "Manual operation only") is cancelled automatically. The actuator then responds to KNX telegrams again.

### How to set the actuator to manual operation

① Press the manual operation key.

The red manual operation LED lights up. The actuator is in manual operation.

- The green operation LED "RUN" goes out when "Manual operation only" is set in the ETS.
- The green operation LED remains lit when "Bus and manual operation" is set in the ETS.

### How to control the channels in manual operation

① To switch channels on and off: Press the corresponding channel key.

The corresponding channel status LED lights up when the relay is closed.

### How to end manual operation

① Press the manual operation key again.

The red manual operation LED goes out. The green operation LED lights up. The actuator now only responds to KNX telegrams.

## What should I do if there is a problem?

### The red manual operation LED and the green operation LED are not lit. Manual operation cannot be activated.

Cause	Solution
Bus and mains voltage have failed.	Check both

### The green operation LED is not lit.

Cause	Solution
The bus voltage has failed.	Check bus voltage; only manual operation is possible
Application was not loaded properly.	Load it again

### The green operating LED does not light up, the red manual operation LED lights up.

Cause	Solution
Manual operation is active and "Manual operation only" is set in the ETS. Only manual operation is possible. There is no fault.	Switch off manual operation

### Actuator does not react to the manual operation key, the red manual operation LED does not light up, manual mode is not possible.

Cause	Solution
ETS parameter "Manual operation enabled" is set to "blocked". There is no fault.	Set the "Manual operation enabled" parameter to "enabled/enable"
"Manual operation enabled" is blocked by an object (value=0), there is no fault.	Enable manual operation via object

### In manual operation, the actuator does not react to the activation of the channel keys, the red manual operation LED lights up, manual mode is not possible.

Cause	Solution
The green operating LED is still lit: The ETS parameter "Manual operating mode" is set to "Bus and manual operation", a prioritised function (e.g. block) is activated, there is no fault.	Wait until the higher-level function has been completed, or switch the ETS parameter "Manual operation type" to "Manual operation only". Please refer to the safety note in the "Operating the actuator" section.
The green operating LED is not lit: Bus voltage has failed and the ETS parameter "Manual operation when bus voltage fails" has been "blocked".	Check bus voltage

### In manual operation, the actuator controls connected loads without a channel key being pressed.

Cause	Solution
The ETS parameter "Manual operating mode" is set to "Bus and manual operation". The control command for the actuator came via a KNX telegram. There is no fault.	Switch the ETS parameter "Manual operating mode" to "Manual operation only". Please refer to the safety note in the "Operating the actuator" section.

## When and how the LEDs light up

RUN (green)	Manual (red)	Channel status (yellow)	
On	-	-	Normal operation
-	On	-	Manual operation (ETS: manual operation only)
On	On	-	Manual operation (ETS: bus and manual operation)

### Statuses of the LEDs relative to the supply voltage

RUN (green)	Manual (red)	Channel status (yellow)	
On	lights up on manual operation	lights up on action	Mains and bus voltage or bus voltage only
-	lights up on manual operation	lights up on action	mains voltage only

## Technical data

External auxiliary voltage:	AC 110 – 240 V, 50 – 60 Hz, max. 2 VA
Supply from KNX:	DC 24 V, max. 175 mA
Nominal voltage:	AC 230 V
Per channel	
Nominal current:	10 A, ohmic $\cos \varphi = 1$ 10 A, inductive $\cos \varphi = 0.6$
Capacitive load:	10 A, max. 105 $\mu\text{F}$
Incandescent lamps:	AC 230 V, max. 2000 W
Halogen lamps:	AC 230 V, max. 1700 W
LV halogen lamps with wound transformer:	AC 230 V, 250 VA
Fluorescent lamps:	AC 230 V, max. 1800 W uncompensated, AC 230 V, max. 1000 W parallel-compensated
Motor load:	AC 230 V, max. 1000 W
Switching frequency:	max. 15 times per minute at nominal load
Fuse:	per channel one 10 A circuit breaker connected upstream; only one live conductor may be used per connecting terminal
Ambient temperature	
Operation:	-5 °C to +45 °C
Storage:	-25 °C to +55 °C
Transport:	-25 °C to +70 °C
Environment:	can be used at up to 2000 m above sea level (MSL)
Max. humidity:	93 %, no moisture condensation
Operating elements:	1 programming button, 1 "Manual" manual operation key, 1 channel key per channel
Display elements:	1 red LED: Programming check, 1 green LED: ready for operation, "RUN", 1 red LED: manual operation status, 1 yellow status LED per channel
KNX connection:	two 1 mm pins for bus connecting terminal
Mains connection:	4-gang screw terminals for max. 2.5 mm <sup>2</sup> 2 x L / 2 x N
Load connection:	per 2 channels one plug-in 4-gang screw terminal for max. 2.5 mm <sup>2</sup>
Device width:	6 depth units = approx. 108 mm

## Schneider Electric Industries SAS

If you have technical questions, please contact the Customer Care Center in your country.

[www.schneider-electric.com](http://www.schneider-electric.com)

This product must be installed, connected and used in compliance with prevailing standards and/or installation regulations. As standards, specifications and designs develop from time to time, always ask for confirmation of the information given in this publication.